

# High-Performance Heterodyne Optical Injection Phase-Lock Loop Using Wide Linewidth Semiconductor Lasers

C. Walton, A. C. Bordonalli, and A. J. Seeds, *Fellow, IEEE*

**Abstract**—The requirements for narrow linewidth lasers or short-loop propagation delay limit optical phase-lock loop realizability with semiconductor lasers. Although optical injection locking can provide low-phase-error variance, its locking range is limited by stability considerations. The first experimental results for an heterodyne optical injection phase-lock loop are reported. Phase-error variance as low as  $0.003 \text{ rad}^2$  in a bandwidth of 100 MHz, single-sideband (SSB) noise density of  $-94 \text{ dBc/Hz}$  at 10-kHz offset and mean time to cycle slip of  $3 \times 10^{10} \text{ s}$  have been achieved using DFB lasers of 36-MHz summed linewidth, a loop propagation delay of 20 ns and an injection ratio of  $-30 \text{ dB}$ .

**Index Terms**—Injection locking, linewidth, optical communication, optical phase-lock loop, semiconductor laser.

## I. INTRODUCTION

OPTICAL phase-lock loop (OPLL) and optical injection locking (OIL) techniques have been extensively used to achieve frequency synchronization of semiconductor lasers in optical communication systems [1], [2] and for signal generation in microwave opto-electronic systems [3]–[5]. Although the utilization of semiconductor lasers without line narrowing techniques would permit the realization of compact and low-cost systems, their relatively wide linewidth requires very short loop propagation delay in heterodyne and homodyne OPLL's to achieve acceptable phase noise reduction [6]. OIL systems eliminate the loop delay restriction and the level of phase noise can be controlled by the injection level into the slave laser. However, the useful part of the OIL locking range can be severely reduced due to instabilities occurring in the locking process above critical levels of injection [7].

It has been shown [8] that an homodyne optical injection phase-lock loop (OIPLL) system allows low phase error variance ( $0.006 \text{ rad}^2$  in 500 MHz bandwidth) to be achieved in loops having wide linewidth lasers and significant loop propagation delay (15 ns), offering improved performance over either OPLL or OIL systems used individually. In order to realize an heterodyne OIPLL, offset locking of the slave laser is required; a microwave phase detector to permit comparison with the reference frequency must be incorporated and delay matching techniques for the complete system developed. In

Manuscript received April 24, 1997; revised November 14, 1997. This work was supported by EPSRC, U.K., by ARO, USA, and by CNPq, Brazil.

C. Walton and A. J. Seeds are with the Department of Electronic and Electrical Engineering, University College London, Torrington Place, London, WC1E 7JE, U.K.

A. C. Bordonalli was with the Department of Electronic and Electrical Engineering, University College London, Torrington Place, London, WC1E 7JE, U.K. He is now with DMO-FEEC, UNICAMP, Campinas, SP, 13083-970, Brazil.

Publisher Item Identifier S 1041-1135(98)01866-7.

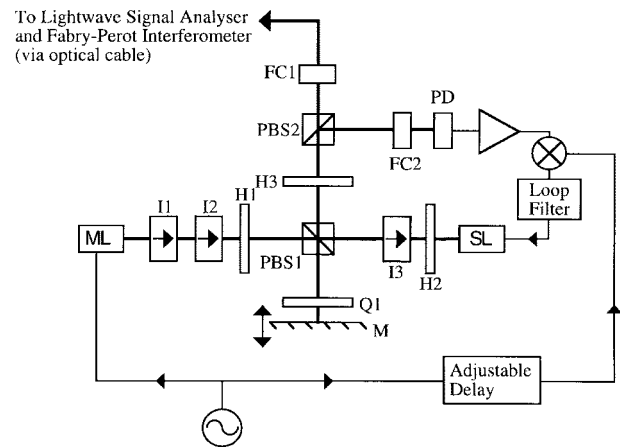

Fig. 1. Experimental arrangement for the OIPLL experiment. ML: master laser; SL: slave laser; I1 to I3: optical isolators; H1 to H3: half-wave plates; Q1: quarter-wave plate; M: mirror; PBS1 and PBS2: polarizing beam splitters; FC: fiber coupler; PD: photodetector.

this letter, the first experimental results for an heterodyne OIPLL, generating microwave carriers at frequencies of 8 or 16 GHz, are presented.

## II. OIPLL SYSTEM

Fig. 1 shows the experimental layout of the heterodyne OIPLL. Offset injection locking was achieved by modulating the master laser ML with the reference frequency and injecting part of the emitted light into the slave laser SL cavity [5]. The isolators I1 and I2 prevent coupling of slave laser emission and back reflections to the master laser. The angle of the half-wave plate H1 controls the injection level. The light transmitted by the polarizing beam splitter PBS1 is horizontally polarized ( $0^\circ$ ) and is injected into the slave laser after passing through I3 (which has the front polarizer removed) and H2, both set in such a way that the resulting polarization direction of the beam is still  $0^\circ$ . The other part of the master laser beam is reflected by PBS1 with vertical polarization ( $90^\circ$ ) and reflected back by the mirror M, passing twice through the quarter-wave plate Q1. Therefore, the polarization state of the returning beam is rotated  $90^\circ$  in relation to the initial condition and the beam is fully transmitted through PBS1 toward the half-wave plate H3. The polarization direction of the slave laser emission is  $0^\circ$ . After H2 and I3, the slave laser beam polarization is  $90^\circ$  and, therefore, it is fully reflected by PBS1 toward half-wave plate H3. The two beams from master and slave lasers are orthogonal at H3, which is aligned at  $45^\circ$  with respect to the two beams. The two beams pass through the combination of H3 and PBS2, ensuring the same polarization for the beams

being coupled into the fiber couplers FC1 and FC2 and giving high efficiency in the wave-front overlap. An optical fiber cable with a 3-dB coupler is used to take the signal from FC1 to both a Fabry–Perot interferometer FPI (Burleigh HF-1500-2) and a lightwave signal analyzer LSA (HP 70 810B). The reflected beam from PBS2 passes to FC2 and then to a 60-GHz bandwidth photodiode (NewFocus 1014). The principal beat signal generated at the photodiode is between the master laser fundamental and the slave laser fundamental. The photodiode output passes through two microwave integrated circuit amplifiers of total gain 50 dB and is compared with the reference frequency in a diode ring mixer. The loop filter gives a second-order type II characteristic with transfer function  $F(s) = (1 + s\tau_2)/s\tau_1$ , where  $\tau_1$  and  $\tau_2$  are the filter time constants [9]. The filter output is converted to current by means of a transconductance amplifier and added to the slave laser bias, tuning the slave laser to minimize the phase error in the loop.

The transfer function for a locked OIPLL system can be simplified from the results shown in [10] and expressed by

$$H(s) = \frac{\rho \cos \theta_{\text{diff}} + kF(s)e^{-sT_d}}{s + \rho \cos \theta_{\text{diff}} + kF(s)e^{-sT_d}} \quad (1)$$

where  $k$  is the OPLL loop gain,  $F(s)$  is the loop filter transfer function and  $e^{-sT_d}$  represents the effect of the total loop propagation delay  $T_d$ . The OIL process is modeled as a first-order phase-lock loop with loop gain equal to the injection rate  $\rho$ , defined by

$$\rho = \frac{1}{\tau_i} \sqrt{\frac{P_{\text{inj}}}{P}} \quad (2)$$

where  $\tau_i$  is the effective laser cavity round-trip time,  $P_{\text{inj}}$  the injected power and  $P$  the slave laser output power. The injection ratio is defined as  $P_{\text{inj}}/P$ . For side-frequency injection locking,  $P_{\text{inj}}$  is the power of the side-frequency to which the slave laser is locked.

Experimentally, the loop phase error is detected at two physically separate points, at the diode ring mixer phase detector and at the slave laser due to the OIL process. The differential phase  $\theta_{\text{diff}}$  represents the possible phase mismatch due to any difference between the path lengths which will lead to competition between the two locking processes and system instability. Referring to Fig. 2,  $\theta_{\text{diff}}$  is given by

$$\theta_{\text{diff}} = \omega_o \cdot (-t_e + t_c + t_d + t_f + t_b) + \omega_m \cdot (-t_a + t_c + t_b) \quad (3)$$

where the reference frequency is  $\omega_o$ , the master laser frequency is  $\omega_m$ ,  $t_a$  is the delay from master laser to photodiode,  $t_b$  the delay from master laser to slave laser,  $t_c$  the delay from slave laser to photodiode,  $t_d$  the delay from photodiode to mixer,  $t_e$  the delay from oscillator to mixer, and  $t_f$  the delay from oscillator to master laser. The first term in (3) pertains to the OPLL part of the system, and the second term to the OIL part of the system.

Experimentally, the path lengths are matched by translation of mirror M and adjustment of the microwave delay line between oscillator and mixer. To ensure that  $\theta_{\text{diff}} = 0$  for all frequencies, it is necessary that  $t_a = t_b + t_c$ , and that  $t_e = t_b + t_c + t_d + t_f$ . It is clear that the most sensitive path length matching required is for the OIL system since  $\omega_m \gg \omega_o$  (master laser frequency = 200 THz and modulating frequency = 8 GHz).

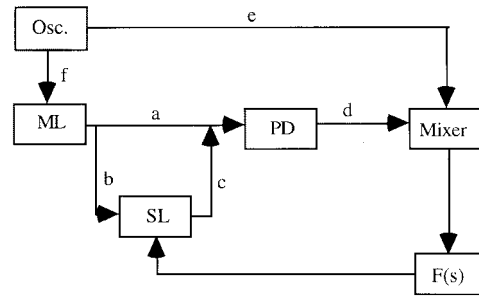

Fig. 2. Path lengths in the OIPLL system for path matching analysis.

The phase error spectrum for an heterodyne OIPLL, assuming shot noise limited detection, and including the phase noise of the optical signals, is obtained from [6], [8]

$$S_e(f) = \frac{\Delta f_{ms}}{2\pi f^2} |1 - H(j2\pi f)|^2 + \frac{e(P_M + P_S)}{2RP_M P_S} |H(j2\pi f)|^2 \quad (4)$$

where  $\Delta f_{ms}$  is the summed FWHM linewidth of the master and slave lasers,  $R$  the photodetector responsivity,  $e$  the electronic charge and  $P_M$  and  $P_S$  the respective master and slave laser optical powers reaching the photodetector. The phase error variance can be obtained by integrating (4) over the required frequency range.

### III. EXPERIMENTAL RESULTS

The master and slave lasers used were buried heterostructure 1.55- $\mu\text{m}$  wavelength DFB lasers that were biased at around 2.75 times threshold current,  $I_{\text{th}}$ , and 2.1 times  $I_{\text{th}}$  producing output optical powers of 5 and 3.6 mW, respectively. Their linewidths were measured by self-homodyne techniques to be 16 and 20 MHz, respectively. Close path matching was obtained by using the experimental setup as a Michelson interferometer [8]. The system was first aligned to increase the reflection of the ML beam by the SL facet. The mirror mounting translation stage was then adjusted until a large area photodetector detecting the PBS3 transmitted signal maintained maximum output for every ML frequency. Electrical path matching was achieved by adjustment of a sliding line in the path from oscillator to mixer.

The first experimental step was to perform the sideband OIL experiment. H1 was rotated such that the level of upper sideband injection ratio was  $-30$  dB. Note that the injection ratio of the master laser fundamental line is considerably higher at  $-23$  dB due to its larger power. In these experiments, the sideband offset frequency had to be greater than 6 GHz to prevent the slave laser locking to the master laser fundamental for these injection levels. The OIL locking range, measured by tuning the master laser by temperature, was less than 2 GHz.

Next, the phase-lock path, with measured loop delay of 20 ns, total loop gain 50 Mrad/s and active loop filter time constants  $\tau_1 = \tau_2 = 100$  ns, was added to the system and measurements of the OIPLL performance made. The detected heterodyne level was  $-60$  dBm and the estimated signal to noise ratio at the phase detector input for large offsets was 106 dBHz, limited by the microwave amplifier noise. Fig. 3 shows the 8-GHz beat between master and slave lasers, having a power spectral density of  $-94$  dBc/Hz at 10-kHz offset and

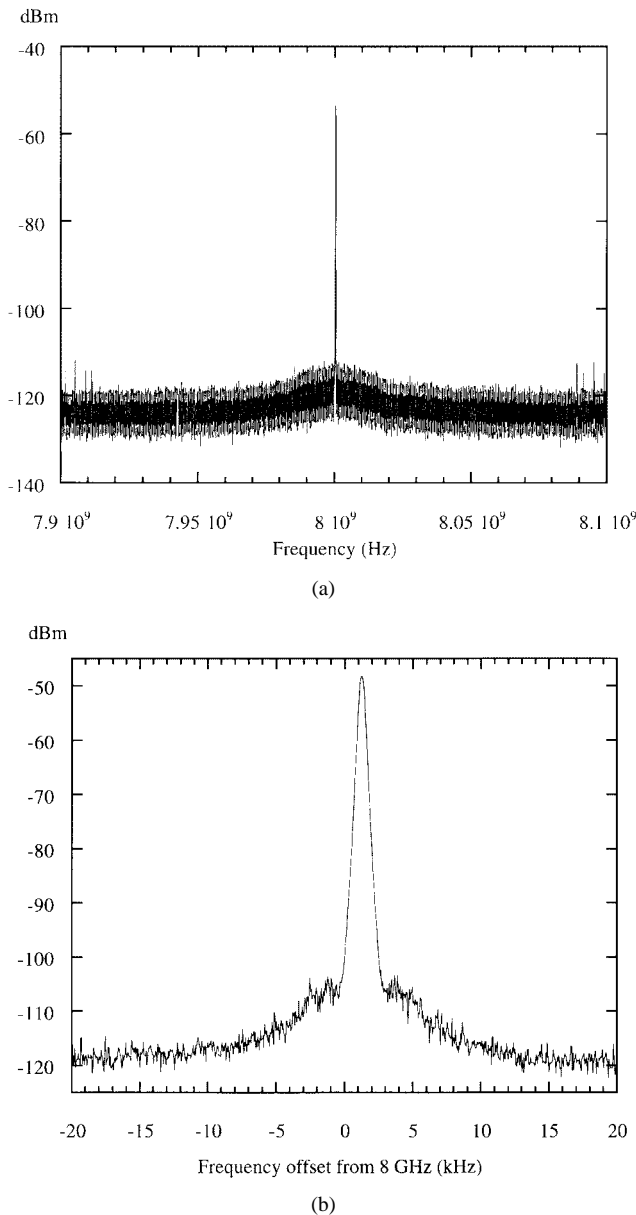

Fig. 3. (a) 8-GHz beat for the heterodyne OIPLL system. Injection ratio:  $-30$  dB. Span = 200 MHz, resolution bandwidth = 3 kHz. (b) Span = 20 kHz; resolution bandwidth = 300 Hz.

variance of  $0.003 \text{ rad}^2$  in a bandwidth of 100 MHz (limited by LSA noise floor). The hold-in range was increased to greater than 24 GHz, and the frequency range by reference oscillator tuning was greater than 200 MHz, limited by loop microwave component bandwidth.

Harmonic locking was also shown to be possible with the OIPLL system. Since modulation of the master laser results in both intensity modulation (IM) and frequency modulation (FM), multiple side frequencies are generated. Injection locking to the second harmonic (16 GHz) offset side-frequency is therefore possible and was achieved with a locking range of less than 1 GHz. With the addition of the OPLL path, the hold-in range was increased to 4 GHz. The hold-in range is lower than for fundamental locking because the injection ratio for the 16-GHz sideband was smaller at  $-37$  dB, resulting in reduced OPLL loop gain.

Finally, it was observed, that in an uncontrolled laboratory environment, the OIPLL remained locked for periods of several hours, with no decrease in phase noise suppression performance. From the measurements of phase error variance, it is estimated that the mean time to cycle slip for the heterodyne OIPLL is  $3 \times 10^{10}$  s, or over 950 years.

#### IV. CONCLUSION

The implementation of the new OIPLL architecture developed at UCL, initially in homodyne form, has been extended to an heterodyne OIPLL operating at 8- or 16-GHz offsets using side-frequency injection locking to a modulated master laser. The combined system offers lower values of phase error variance ( $0.003 \text{ rad}^2$ , 100 MHz bandwidth) and improved stability (mean time to cycle slip of  $3 \times 10^{10}$  s), than is possible with wide linewidth lasers used in conventional OPLL systems, together with wider stable locking range ( $>24$  GHz) than a comparable OIL system ( $<2$  GHz). The tracking capability of the combined OIPLL system is improved compared with the equivalent OPLL and OIL systems, as long term fluctuations can be compensated electronically by the OPLL path while fast fluctuations can be followed by the OIL path. The OIPLL is likely to find application in a number of microwave optoelectronic and dense wavelength division multiplex (DWDM) optical communication systems.

#### ACKNOWLEDGMENT

The authors would like to acknowledge BT Research Laboratories (Dr. D. Wake) for the supply of lasers and helpful discussions.

#### REFERENCES

- [1] L.G. Kazovsky, "Balanced phase-locked loops for homodyne receivers," *J. Lightwave Technol.*, vol. LT-4, pp. 182–195, 1986.
- [2] O. Lidoyne, P. Gallion and D. Erasme, "Analysis of a homodyne receiver using an injection-locked semiconductor laser," *J. Lightwave Technol.*, vol. 9, pp. 659–665, May 1991.
- [3] R. T. Ramos and A. J. Seeds, "Fast heterodyne optical phase-lock loop using double quantum well laser diodes," *Electron. Lett.*, vol. 28, no. 1, pp. 82–83, 1992.
- [4] U. Gliese, T. N. Nielsen, M. Bruun, E. L. Christensen, K. E. Stubkjaer, S. Lindgren, and B. Broberg, "A wideband heterodyne optical phase-locked loop for generation of 3–18 GHz microwave carriers," *IEEE Photon. Technol. Lett.*, vol. 4, pp. 936–938, Aug. 1992.
- [5] L. Goldberg, H. F. Taylor, J. F. Weller, and D. M. Bloom, "Microwave signal generation with injection-locked laser diodes," *Electron. Lett.*, vol. 19, no. 13, pp. 491–493, 1983.
- [6] R. T. Ramos and A. J. Seeds, "Delay, linewidth and bandwidth limitations in optical phase-locked loop design," *Electron. Lett.*, vol. 26, no. 6, pp. 389–391, 1990.
- [7] O. Lidoyne, P. Gallion, C. Chabran, and G. Debarge, "Locking range, phase noise and power spectrum of an injection-locking semiconductor laser," *Proc. Inst. Elect. Eng.*, vol. 137, pt. J, no. 3, pp. 147–154, 1990.
- [8] A. C. Bordonalli, C. Walton, and A. J. Seeds, "High-performance homodyne optical injection phase-lock loop using wide linewidth semiconductor lasers," *IEEE Photon. Technol. Lett.*, vol. 8, pp. 1217–1219, Sept. 1996.
- [9] F. M. Gardner, *Phaselock Techniques*. New York: Wiley, 1979.
- [10] R. T. Ramos, P. Gallion, D. Erasme, A. J. Seeds, and A. C. Bordonalli, "Optical injection locking and phase-lock loop combined systems," *Opt. Lett.*, vol. 19, no. 1, pp. 4–6, 1994.
- [11] R. Hui, A. D'Ottavi, A. Mecozzi, and P. Spano, "Injection locking in distributed feedback semiconductor lasers," *IEEE J. Quantum Electron.*, vol. 27, pp. 1688–1695, June 1991.